

# SBH

## DIRECT DRIVE BLOWER COIL

INSTALLATION & OPERATION MANUAL

**SUPERIOR**

**REX**



SBH



SBV

# TABLE OF CONTENTS

SAFETY SYMBOLS & CONSIDERATIONS: . . . . .	3	SECTION FOUR - DISCRETE COMPONENTS . . . . .	18
SECTION ONE - RECEIPT & INITIAL INSTALLATION		Fan Motor Control . . . . .	18
DIRECT DRIVE BLOWER COIL FEATURES. . . . .	4	Installation . . . . .	18
Preface . . . . .	4	Mounting. . . . .	18
Unpacking & Inspection . . . . .	5	Wiring . . . . .	18
Code Compliance . . . . .	5	Reference Wire Diagram . . . . .	19
Handling And Installation . . . . .	5	Table F.1 – Terminal Strip Identification . . . . .	20
Unit Rigging And Placement . . . . .	6	Tools Needed For Installation/Troubleshooting . . . . .	20
Drain Pan . . . . .	6	Table F.2 – Field Installed Component Descriptions . . . . .	20
Coils . . . . .	7	Table F.3 – Jumper Description . . . . .	20
Cooling/Heating Medium Connections . . . . .	7	Checking Wire Harnesses. . . . .	21
Ductwork Connections . . . . .	7	Table F.4 – Fan Motor Control. . . . .	22
Electrical Connections. . . . .	8	SECTION FIVE - TROUBLESHOOTING . . . . .	23
Electrical Enclosure . . . . .	8	Ec Motor Troubleshooting Guidelines . . . . .	23
Condensate Drain And Traps . . . . .	8	Cooling System Troubleshooting Guidelines . . . . .	23
Model SBH - Service And Clearance Requirements . . . . .	9	Electric Heater Troubleshooting Guidelines. . . . .	24
Model SBH - Service And Clearance Requirements . . . . .	10	SECTION SIX - INSPECTION & START-UP CHECKLIST . . . . .	27
Clearance . . . . .	11	Receiving & Inspection . . . . .	27
Field Wiring . . . . .	11	Handling & Installation. . . . .	27
Table 1: Unit Weight Data (Lbs./Kg) . . . . .	11	Cooling/Heating Connections . . . . .	27
SECTION TWO - START UP . . . . .	12	Ductwork Connections . . . . .	27
General . . . . .	12	Electrical Connections. . . . .	27
Cooling/Heating System. . . . .	12	Unit Startup . . . . .	27
Air System Balancing . . . . .	12	Blower/Motor . . . . .	27
Table 2: EC Motors . . . . .	13		
Water System Balancing . . . . .	13		
Controls Operation . . . . .	13		
SECTION THREE - NORMAL OPERATION & PERIODIC MAINTENANCE. . . . .	14		
General . . . . .	14		
Motor/Blower Assembly . . . . .	14		
Coil . . . . .	15		
Electric Resistance Heater Assembly . . . . .	15		
Electrical Wiring & Controls . . . . .	15		
Filters, Throwaway . . . . .	16		
Table 3: Face Area, Free Area & Filter Sizes . . . . .	16		
Drain. . . . .	17		
Condensate Float Switch Installation . . . . .	17		
Supplier's Install Instructions . . . . .	17		
Replacement Parts . . . . .	17		

## SAFETY SYMBOLS & CONSIDERATIONS:

The following symbols are used in this document to alert the reader to areas of potential hazard:



**DANGER** indicates an imminently hazardous situation which, if not avoided, will result in death or serious injury.



**CAUTION** identifies a hazard which could lead to damage to the machine, damage to other equipment and or environmental pollution. Usually an instruction will be given, together with a brief explanation.



**WARNING** indicates a potentially hazardous situation which, if not avoided, could result in death or serious injury.



**NOTE** is used to highlight additional information which may be helpful to you.

---

The equipment covered by this manual is designed for safe and reliable operation when installed and operated within its design specification limits. To avoid personal injury or damage to equipment or property while installing or operating this equipment, it is essential that qualified, experienced personnel perform these functions using good judgment and safe practices. See the following cautionary statements.



All assemblies must be adequately secured during lifting and rigging by temporary supports and restraints until equipment is permanently fastened and set in its final location.



**ELECTRICAL SHOCK HAZARDS.** All power must be disconnected prior to installation and servicing this equipment. More than one source of power may be present. Disconnect all power sources to avoid electrocution or shock injuries.



All unit temporary and permanent supports must be capable of safely supporting the equipment's weight and any additional live or dead loads that may be encountered. All supports must be designed to meet applicable local codes and ordinances.



**MOVING PARTS HAZARDS.** Motor and Blower must be disconnected prior to opening access panels. Motors can start automatically, disconnect all power and control circuits prior to servicing to avoid serious crushing or dismemberment injuries.



All fastening devices must be designed to mechanically lock the assembly in place without the capability of loosening or breaking away due to system operation and vibration.



**HOT PARTS HAZARD.** Electric Resistance heating elements must be disconnected prior to servicing. Electric Heaters may start automatically, disconnect all power and control circuits prior to servicing to avoid burns.



Secure all dampers when servicing damper, actuator or linkages. Dampers may activate automatically, disconnect control circuits or pneumatic control systems to avoid injury.



Check that the unit assembly and component weights can be safely supported by rigging and lifting equipment.



Protect adjacent flammable materials when brazing. Use flame and heat protection barriers where needed. Have fire extinguisher available and ready for immediate use.

## SECTION ONE - RECEIPT & INITIAL INSTALLATION DIRECT DRIVE BLOWER COIL FEATURES

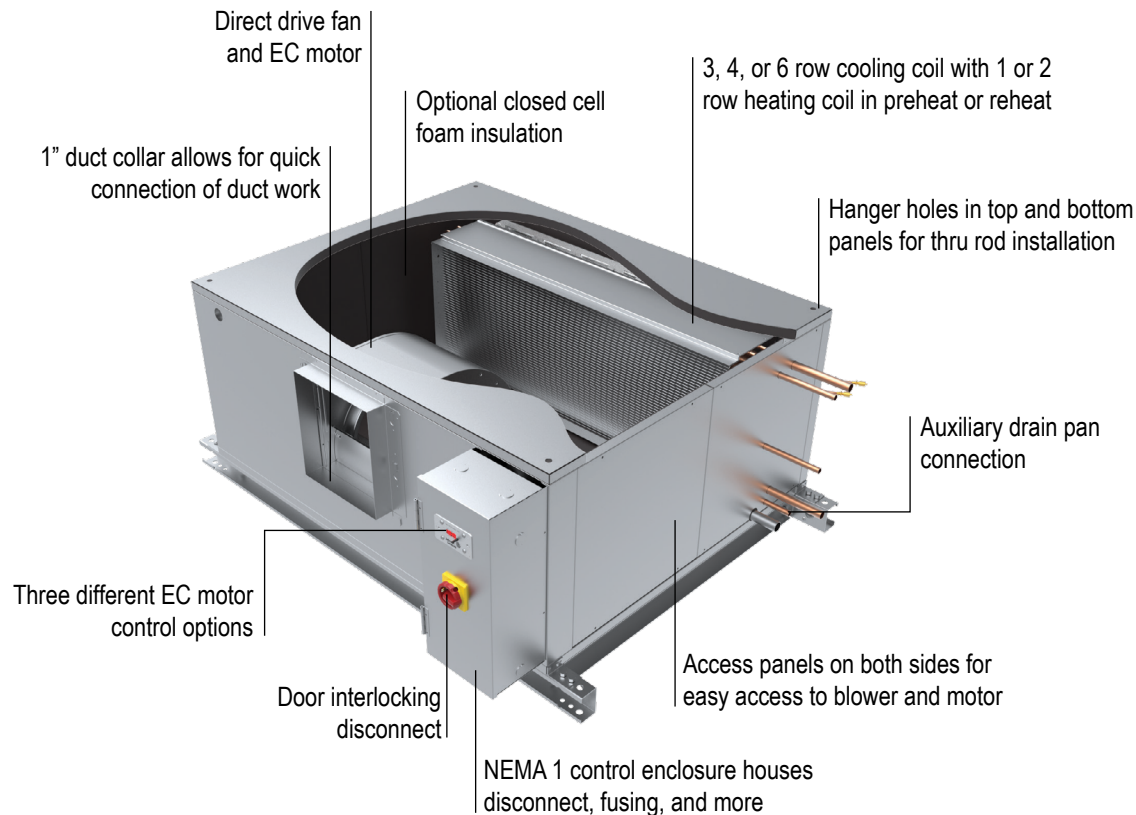

### PREFACE

Superior Rex direct drive blower-coils represent a prudent investment which can, with proper installation, operation, and regular maintenance, give trouble-free operation and long service.

Your equipment is initially protected under the manufacturer's standard warranty; however, this warranty is provided under the condition that the steps outlined in this manual for initial inspection, proper installation, regular periodic maintenance, and everyday operation of the equipment be followed in detail. This manual should be fully reviewed in advance of any actual work being done on the equipment. Should any questions arise, please contact your local Sales Representative BEFORE proceeding.

The equipment covered by this manual is available with a vast variety of options and accessories. Consult the approved unit submittal, order acknowledgment, and other manuals for details on the options and accessories provided with the equipment on each project.



No attempt should be made to handle, install, or service any unit without following safe practices regarding mechanical equipment.



All power must be disconnected before any installation or service should be attempted. More than one power source may be supplied to a unit. Power to remote mounted control devices may not be supplied through the unit. Never wear bulky or loose fitting clothing when working on any mechanical equipment. Gloves should only be worn when required for proper protection from heat or other possible injury. Safety glasses or goggles should always be worn when drilling, cutting, or working with chemicals such as refrigerants or lubricants.



Never pressurize any equipment beyond specified operating pressures. Always pressure test with some inert fluid or gas such as clear water or dry nitrogen to avoid possible damage or injury in the event of a leak or component failure during testing.



Always protect adjacent flammable material when welding, brazing or soldering. Use suitable heat shield material to contain sparks or drops of solder. Have fire extinguisher available for use when welding or brazing.

The manufacturer assumes no responsibility for personal injury or property damage resulting from improper or unsafe practices during the handling, installation, service, or operation of any equipment.

## UNPACKING & INSPECTION

All units are carefully inspected at the factory throughout the manufacturing process under a strict detailed quality assurance program, and where possible, all major components and sub assemblies are carefully tested for proper operation and verified to be in full compliance with the factory manufacturing documents. Customer furnished components such as control valves, switches and DDC controls are not factory tested.

Each unit is carefully packaged for shipment to avoid damage during normal transport and handling. The equipment should always be stored in a dry place in the proper orientation as marked on the carton.

All shipments are made F.O.B. factory and it is the responsibility of the receiving party to inspect the equipment upon arrival. Any obvious damage to the carton and/or its contents should be recorded on the bill of lading and a claim should be filed with the freight carrier.

After determining the condition of the carton exterior, carefully remove each unit from the carton and inspect for hidden damage. At this time check to make sure that "furnished only" items such as switches, thermostats, etc., are accounted for. Any hidden damage should be recorded and immediately reported to the carrier and a claim must be filed. In the event a claim for shipping damage is filed, the unit, shipping carton, and all packing must be retained for physical inspection by the freight carrier. All equipment should be stored in the factory-shipping carton with internal packing in place until installation.

At the time of receipt, the equipment type and arrangement should be verified against the order documents. Should any discrepancy be found, the local Sales Representative should be notified immediately so that the proper action may be instituted. Should any question arise concerning warranty repairs, the factory must be notified BEFORE any corrective action is taken. Where local repairs or alterations can be accomplished, the factory must be fully informed as to the extent and expected cost of those repairs before work is begun. Where factory operations are required, the factory must be contacted for authorization to return equipment and a Return Authorization Number will be issued. Unauthorized return shipments of equipment and shipments not marked with an authorization number will be refused. In addition, the manufacturer will not accept any claims for unauthorized expenses.

## CODE COMPLIANCE

This equipment has been manufactured and certified to conform to UL Standard for Heating and Cooling Equipment, UL 1995 (4th Edition) and to CSA Standard C22.2 No. 236. It bears the ETLc listed mark under Intertek Client #41629.

## HANDLING AND INSTALLATION

While all equipment is designed for durability and fabricated for sturdy construction and may present a rugged appearance, great care must be taken to assure that no force or pressure be applied to the coil, piping or drain stub-outs during handling. Also, depending on the options and accessories, some units could contain delicate components that may be damaged by improper handling. Wherever possible, all units must be maintained in an upright position and handled by the chassis as close as possible to the mounting point locations.

The equipment covered in this manual IS NOT suitable for outdoor installations. The equipment should never be stored or installed where it may be subjected to a hostile environment such as rain, snow, or extreme temperatures.

During and after installation, special care must be taken to prevent foreign material such as paint, plaster, and drywall dust from being deposited in the drain pan, coil, or on the motor or blower wheels. Failure to do so may have serious adverse effects on unit operation and in the case of the motor and blower assembly, may result in immediate or premature failure. All manufacturers' warranties are void if foreign material is allowed to be deposited on the motor or blower wheels of any unit. Some units and/or job conditions may require some form of temporary covering during construction.

While the manufacturer does not become involved in the design and selection of support methods and components, it should be noted that unacceptable system operating characteristics and/or performance may result from improper or inadequate unit structural support. In addition, adequate clearance must be provided for service and removal of the equipment and its accessory components. Anchoring the equipment in place is accomplished by using the mounting points provided and positioning the unit to maintain the unit on a LEVEL plane. The drain pan is internally sloped toward the outlet connection. Care must be taken to insure that the unit drain pan does not slope away from the outlet connection.



The unit's drain pan is factory sloped toward the drain connection when the unit is installed level and plumb.

#### UNIT RIGGING AND PLACEMENT

Install ductwork to comply with ASHRAE Fundamentals Handbook, SMACNA, NFPA 90A and local code.

The installation must conform with local building codes and the National Electric Code.

Locate unit support in accordance with the mechanical and structural plans. If so equipped, locate the isolator placement and correct size as shown on the submittal drawing.

Ceiling suspension of horizontal units have factory provisions for thru bolt hanger rods. If floor mount isolators are required for either horizontal or vertical units, then factory or field provisions must be made for isolator attachment. Vertical units can be mounted directly to the floor or on a base rail. For units with isolators but no base rail, 6" legs are required and will need to be mounted to the base of the unit. If a base rail is provided, isolators can be installed in mounting holes provided on this base rail.

Do not handle the unit using coil stub out connectors, as damage may occur at brazed joint(s).



Figure 1a: Side view

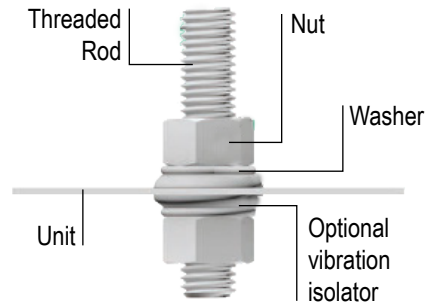

Figure 1b: Installation detail

Figure 1a - 1b: Typical ceiling installation

#### DRAIN PAN

Standard drain pans are constructed of single wall galvanized steel (with an option for stainless steel) and sit on insulation. The drain protrudes from the unit cabinet and can be equipped with a secondary drain connection. See illustration below.

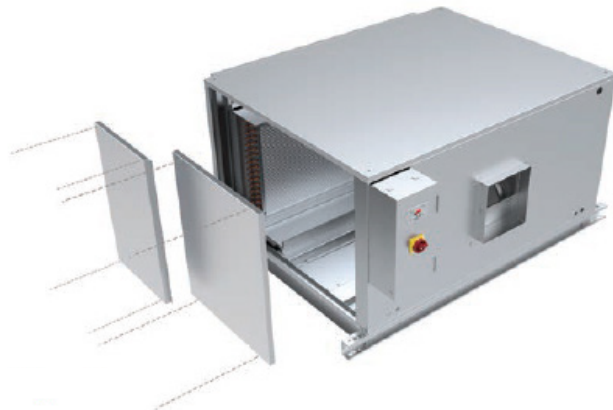
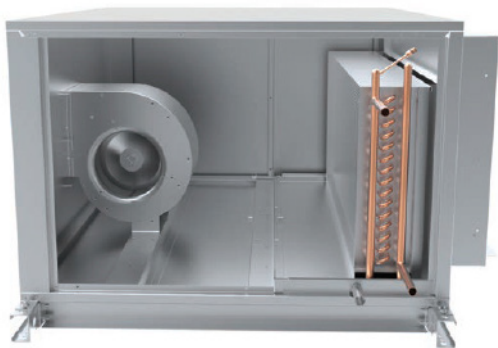

Figure 2a

## COILS

All blower-coils are available in 2 or 4 pipe configurations. Heating coils are available in reheat or preheat position. Heating and cooling coils are available with right, left or opposite side connections.

Verify that the proper types of service are actually provided to the unit. On units with steam heating coils, the maximum steam pressure applied to the unit should never exceed 15 PSIG. The drain piping and steam trap should be sized and routed to allow for proper condensate flow. The routing and sizing of all piping, and the type and sizing of all wiring and other electrical components such as circuit breakers, disconnect switches, etc., should be determined by the individual job requirements and should not be based on the size and/or type of connection provided on the equipment. All installations should be made in compliance with all governing codes and ordinances. Compliance with all codes is the responsibility of the installing contractor.



## COOLING/HEATING MEDIUM CONNECTIONS



Toxic residues and loose particles resulting from manufacturing and field piping techniques such as joint compounds, soldering flux, and metal shavings may be present in the unit and the piping system. Not for use with domestic or potable water systems.

Submittals and Product Catalogs detailing unit operation, controls, and connections should be thoroughly reviewed BEFORE beginning the connection of the various cooling and/or heating mediums to the unit.

All accessory valve packages are to be field provided and installed as required and all service valves should be checked for proper operation. Refer to the valve component manufacturer's IOM manual for proper installation, troubleshooting, and operational guidance.



All water coils must be protected from freezing after initial filling with water. Even if the system is drained, unit coils may still hold enough water to cause damage when exposed to temperatures below freezing.

Refrigerant systems should be tested with dry nitrogen rather than air to prevent the introduction of moisture into the system. In the event that leaking or defective components are discovered, the Sales Representative must be notified BEFORE any repairs are attempted. All leaks should be repaired before proceeding with the installation.

## DUCTWORK CONNECTIONS

All ductwork and/or supply and return grilles (provided by others) should be installed in accordance with the project plans and specifications. If not included on the unit or furnished from the factory, Superior Rex supply and return grilles are available in a variety of types.

Units are configured from the factory with duct collars for attaching ductwork. The factory suggests using galvanized sheet metal ductwork or a flexible canvas attached to the duct collars using sheet metal screws.

Duct connections should follow SMACNA standards and national and local codes.

All units must be installed in non-combustible areas. Some models are designed to be connected to duct-work with a MINIMUM amount of external static pressure.

Consult the approved submittals and the product catalog for unit external static pressure limitations.

Units provided with outside air for ventilation should have some form of low temperature protection to prevent coil freeze-up.

It should be noted that none of these methods would adequately protect a coil in the event of power failure. The safest method of freeze protection is to use glycol in the proper percent solution for the coldest expected air temperature.

The manufacturer assumes no responsibility for undesirable system operation due to improper design, equipment or component selection, and/or installation of ductwork, grilles, and other field supplied components.

## ELECTRICAL CONNECTIONS

The unit nameplate lists the unit electrical characteristics such as the required supply voltage, fan and heater amperage and required circuit ampacities. The unit-wiring diagram shows all unit and field wiring connection points. Since each project is different and each unit on a project may be different, the installer must be familiar with the wiring diagram and nameplate on the unit BEFORE beginning any wiring. This unit is not acceptable for installation in hazardous/explosive areas.

## ELECTRICAL ENCLOSURE



The electrical control enclosure provides access to the electrical compartment. This compartment houses all electric heat and control components. Terminals are furnished for simple power and control wiring connections. Multiple knockouts allow wiring entries from either side of the compartment.

All components furnished for field installation, by either the factory or the controls contractor should be located and checked for proper function and compatibility. All internal components should be checked for shipping damage. After installation and before energizing the unit, verify voltage and check that all electrical connections are tight. Electrical connections should be periodically checked for tightness.

Any devices such as fan switches or thermostats that have been furnished from the factory for field installation must be wired in strict accordance with the applicable wiring diagrams. For electrical devices that are field mounted and provided by others, please refer to the original manufacturer's IOM for proper installation, troubleshooting and operation guidance. Failure to do so could result in personal injury or damage to components and will void all manufacturer's warranties.

All field wiring should be done in accordance with governing codes and ordinances. Any modification of the unit wiring without factory authorization will result in voiding of all factory warranties and will nullify any agency listings. The manufacturer assumes no responsibility for any damages and/or injuries resulting from improperly field installed or wired components.

This unit is listed to UL/CSA standards. All modifications to line voltage wiring must be performed in accordance with the NEC and inspected by ETL to maintain product listing. Unauthorized modification to any wiring may impact unit performance and void ETL listing and/or product warranty.

## CONDENSATE DRAIN AND TRAPS

Drain lines should be at least the same size as the drain pan connection. Properly sized traps should be used to allow the condensate from the coils to drain from the drain pan. See Fig. 4.

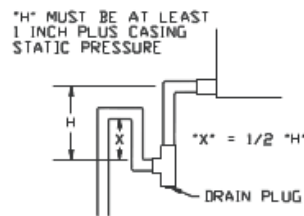

Trap detail for negative cabinet static pressure

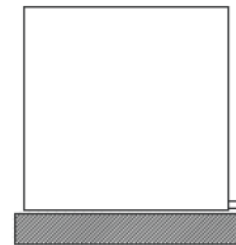

NO BASE RAIL  
Housekeeping pad required to accommodate trap height

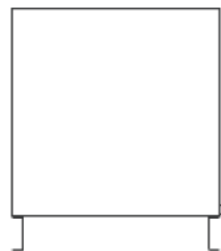

WITH BASE RAIL  
Depending on static pressure, housekeeping pad may not be needed for trap installation

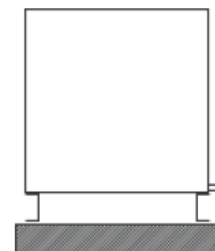

WITH BASE RAIL AND HOUSEKEEPING PAD

Figure 4: Condensate drain & traps



## MODEL SBH - SERVICE AND CLEARANCE REQUIREMENTS

### Notes

1. All dimensions are inches [mm]. All dimensions are +/- 1/4" [6mm]. Metric values are soft conversions
2. Right-hand unit shown, left-hand unit opposite. Motor/drive location may be specified left-hand or right-hand. Standard-control enclosure location matches motor/drive position.
3. Provide sufficient clearance to permit access to controls and comply with applicable codes and ordinances
4. Flat filter rack may be located at unit inlet as required. See drawing BC-SBHD-16.0 for filter rack details.

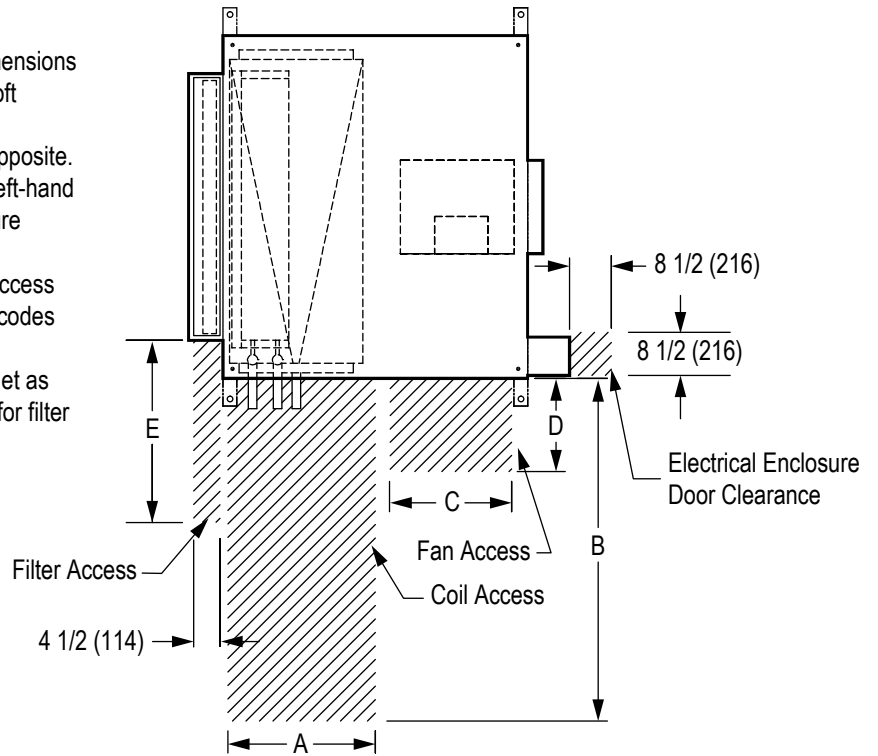

**Top View**

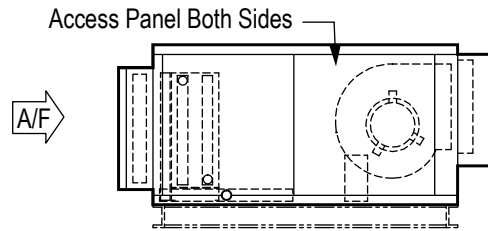

**Side View**

Dimensions					
Size	A	B	C	D	E
08	18 3/4 (476)	30 (762)	17 3/4 (451)	17 3/4 (451)	20 (508)
12	18 3/4 (476)	36 (914)	17 3/4 (451)	17 3/4 (451)	20 (508)
16	18 3/4 (476)	44 (1118)	17 3/4 (451)	17 3/4 (451)	20 (508)
20	18 3/4 (476)	50 (1270)	17 3/4 (451)	17 3/4 (451)	20 (508)
30	27 3/4 (702)	59 (1499)	27 3/4 (705)	27 3/4 (705)	20 (508)
40	27 3/4 (702)	68 (1727)	27 3/4 (705)	27 3/4 (705)	20 (508)

## MODEL SBH - SERVICE AND CLEARANCE REQUIREMENTS

### Notes

1. All dimensions are inches [mm]. All dimensions are +/- 1/4" [6mm]. Metric values are soft conversions
2. Right-hand unit shown, left-hand unit opposite. Motor/drive location may be specified left-hand or right-hand. Standard-control enclosure location matches motor/drive position.
3. Provide sufficient clearance to permit access to controls and comply with applicable codes and ordinances
4. Flat filter rack may be located at unit inlet as required. See drawing BC-SBHD-16.0 for filter rack details.

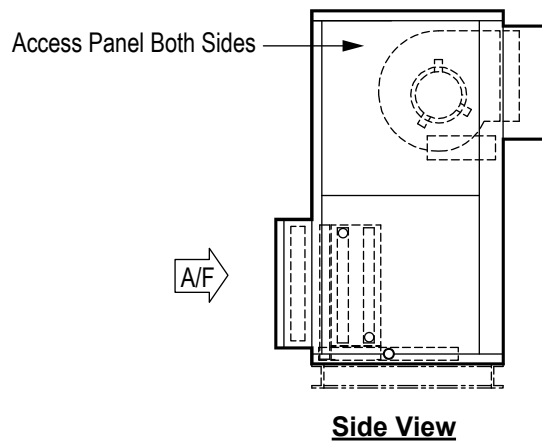
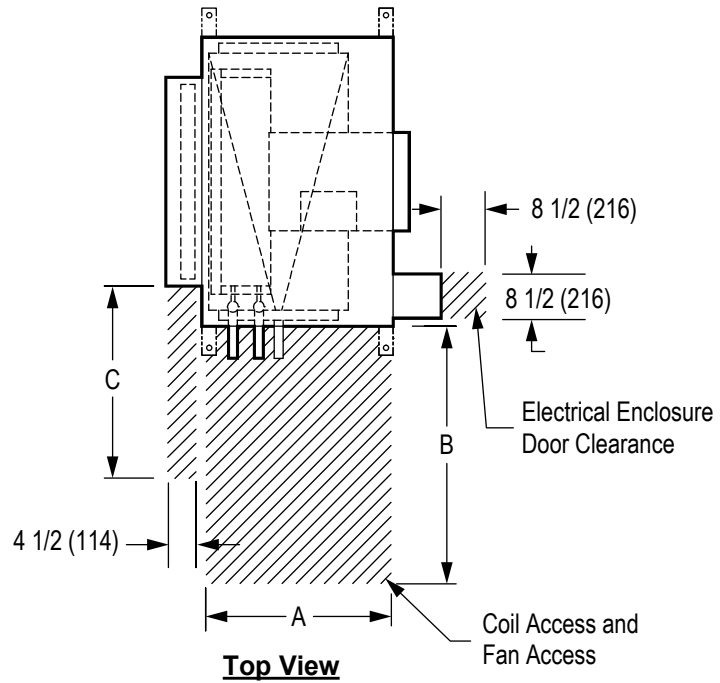

Dimensions			
Size	A	B	C
08	19 (483)	30 (762)	20 (508)
12	19 (483)	36 (914)	25 (635)
16	19 (483)	44 (1118)	20 (508)
20	25 (635)	50 (1270)	20 (508)
30	25 (635)	59 (1499)	20 (508)
40	25 (635)	68 (1727)	20 (508)

## CLEARANCE

All units, including those with electric heat, are listed for zero clearance to combustibles.

Sufficient clearance for normal servicing of this equipment is recommended.

All electrical panels must have 36" working space in front of panel to meet National Electric Code; however, local inspectors may waive this requirement if the hinged cover has a 90° free swing.

## FIELD WIRING



Prior to installing any wiring, check the unit name plate for main power voltage, control voltage, transformer sizing and any fuse sizing. All field wiring must comply with National Electric Code and local code requirements.

Tighten all wiring lugs and terminals prior to connecting power to the unit, as they may loosen during transportation.

Route the power lines to the power distribution terminals inside the control enclosure. If a factory wired disconnect switch is installed, then connect the power lines to the line side of the switch.

Mount and wire any field installed items as indicated on the factory supplied wiring diagram. When mounting field installed components, do not jumper out or rewire any factory wiring without written approval from Superior Rex. Violation will void warranty.

TABLE 1: UNIT WEIGHT DATA (LBS./KG)

Component	Unit Size								
	08	12	16	20	30 (Single Blower)	40 (Single Blower)	30 (Dual Blower)	40 (Dual Blower)	
Base Unit	115 (52)	133 (60)	152 (69)	175 (79)	287 (130)	305 (139)	357 (162)	375 (170)	
Mixing Box	46 (21)	54 (25)	65 (30)	90 (41)	105 (48)	105 (48)	162 (74)	162 (74)	
Blow Thru Electric Heater	42 (19)	42 (19)	55 (25)	55 (25)	55 (25)	125 (57)	55 (25)	125 (57)	
Coil Rows	1 Row - Dry	12 (5)	14 (6)	17 (8)	21 (10)	26 (12)	26 (12)	32 (15)	32 (15)
	1 Row - Wet	14 (6)	16 (7)	20 (9)	25 (11)	32 (15)	32 (15)	41 (19)	41 (19)
	2 Row - Dry	17 (8)	21 (10)	26 (12)	33 (15)	42 (19)	42 (19)	52 (24)	52 (24)
	2 Row - Wet	21 (10)	26 (12)	32 (15)	42 (19)	54 (24)	54 (24)	69 (31)	69 (31)
	3 Row - Dry	23 (10)	28 (13)	35 (16)	45 (20)	57 (26)	57 (26)	72 (33)	72 (33)
	3 Row - Wet	29 (13)	36 (16)	44 (20)	59 (27)	75 (34)	75 (34)	95 (43)	95 (43)
	4 Row - Dry	29 (13)	35 (16)	44 (20)	57 (26)	73 (33)	73 (33)	91 (41)	91 (41)
	4 Row - Wet	37 (17)	45 (20)	56 (25)	74 (34)	96 (44)	96 (44)	121 (55)	121 (55)
	6 Row - Dry	40 (18)	49 (22)	62 (28)	81 (37)	104 (47)	104 (47)	132 (60)	132 (60)
6 Row - Wet	52 (24)	64 (29)	81 (37)	106 (48)	138 (63)	138 (63)	178 (81)	178 (81)	

Note: Unit weight data is shipping weight in pounds (kilograms)

## SECTION TWO - START UP

### GENERAL

Before beginning any start-up operation, the startup personnel should familiarize themselves with the unit, options and accessories, and control sequence to understand the proper system operation. All personnel should have a good working knowledge of general start-up procedures and have the appropriate start-up and balancing guides available for consultation.

The initial step in any startup operation should be a final visual inspection. All equipment, plenums, ductwork, and piping should be inspected to verify that all systems are complete and properly installed and mounted per ASHRAE and SMACNA guidelines, and that no debris or foreign articles such as paper or drink cans are left in the units or other areas. Each unit should be checked for loose wires and hardware, free blower wheel operation, and loose or missing access panels or doors. Except as required during start-up and balancing operations, no blower-coil units should be operated without all the proper ductwork attached, supply and return grilles in place, and all access doors and panels in place and secure. A clean filter of the proper size and type (as provided by factory or replacement matching the original factory size and type) must also be installed. Failure to do so could result in damage to the equipment or building and furnishings, and/or void all manufacturers' warranties.

Blower-coils are not intended for temporary heat/cool or ventilation. Units are not designed or equipped to operate in dusty construction environments. Operation of the units in conditions outlined above could result in damage to the equipment or building and furnishings and/or void all manufacturer's warranties.

### COOLING/HEATING SYSTEM

Prior to the water system start-up and balancing, the chilled/hot water systems should be flushed to clean out dirt and debris, which may have collected in the piping during construction. During this procedure, all unit service valves must be in the closed position. This prevents foreign matter from entering the unit and/or clogging the valves and metering devices. Strainers should be installed in the piping mains to prevent this material from entering the units during normal operation. During system filling, air venting from the unit is accomplished by the use of the standard manual, or optional automatic, air vent fitting installed on the coil. In the case of the manual air vent fitting, the screw should be turned counterclockwise no more than 1 1/2 turns to operate the air vent. Automatic air

vents may be unscrewed one turn counterclockwise to speed initial venting but should be screwed in for automatic venting after start-up operations. Check to ensure that no leaks are prevalent at the coils, coil connections, piping packages, etc.



The air vent provided on the unit is not intended to replace the main system air vents and may not release air trapped in other parts of the system. Inspect the entire system for potential air traps and vent those areas as required, independently. In addition, some systems may require repeated venting over a period of time to properly eliminate air from the system.

### AIR SYSTEM BALANCING

All duct-work must be complete and connected, and all grilles, filters, access doors and panels must be properly installed to establish actual system operating conditions BEFORE beginning air balancing operations.

Each individual unit and attached duct-work is a unique system with its own operating characteristics. For this reason, air balancing is normally done by balance specialists who are familiar with all procedures required to properly establish air distribution and fan system operating conditions. These procedures should not be attempted by unqualified personnel. Some selections may require air balancing in the field.

After the proper system operation is established, the actual unit air delivery and the actual fan motor amperage draw for each unit should be recorded in a convenient place for future reference such as the inspection, installation, & start-up check sheet, a copy of which is provided on the back of this manual. Contact the Sales Representative for additional copies of this sheet.

TABLE 2: EC MOTORS

Horsepower	Maximum Motor Amperage						
	Voltage / Phase						
	115/1	208/1	230/1	277/1	208/3	230/3	480/3
1/2	7.7	5.0	5.0	4.1	2.0	2.0	1.0
1	12.8	9.4	9.4	6.9	3.7	3.7	1.7
1 1/2 <sup>3</sup>	-	-	-	-	4.4	4.4	2.2
2 <sup>3</sup>	25.6	18.8	18.8	13.8	7.4	7.4	3.4
3 <sup>3</sup>	-	-	-	-	8.8	8.8	4.4

Notes:

1. Actual motor nameplate AMPs may vary, but will not exceed values shown
2. Consult factory for applications requiring special motors
3. Amp values are total amp values for (2) motors

WATER SYSTEM BALANCING

A complete knowledge of the hydronic system, its components, and controls is essential to proper water system balancing and this procedure should not be attempted by unqualified personnel. The system must be complete and all components must be in operating condition BEFORE beginning water system balancing operations.

Each hydronic system has different operating characteristics depending on the devices and controls in the system. The actual balancing technique may vary from one system to another.

After the proper system operation is established, the appropriate system operating conditions such as various water temperatures and flow rates should be recorded in a convenient place for future reference.

Before and during water system balancing, conditions may exist which can result in noticeable water noise or undesired valve operation due to incorrect system pressures. After the entire system is balanced, these conditions will not exist on properly designed and balanced systems.

CONTROLS OPERATION

Before proper control operation can be verified all other systems must be in proper operation. The correct water and air temperatures must be present for the control function being tested. Some controls and features are designed to not operate under certain conditions.

A wide range of controls and electrical options and accessories may be used with the equipment covered in this manual. Consult the approved unit submittals, order acknowledgment, and other manuals for detailed information regarding each individual unit and its controls. Since controls and features may vary from one unit to another, care should be taken to identify the controls to be used on each unit and their proper control sequence information provided by component manufacturers such as submittals and installation, operation, and maintenance manuals of their individual controls is available upon request.

## SECTION THREE - NORMAL OPERATION & PERIODIC MAINTENANCE

### GENERAL

Each unit on a job will have its own unique operating environment and conditions that may dictate a maintenance schedule for that unit that is different from other equipment on the job. A formal schedule of regular maintenance and an individual unit log should be established and maintained. This will help to achieve the maximum performance and service life of each unit on the job.



Information regarding safety precautions contained in the preface at the beginning of this manual should be followed during any service and maintenance operations.

For more detailed information concerning service operations, consult your Sales Representative.

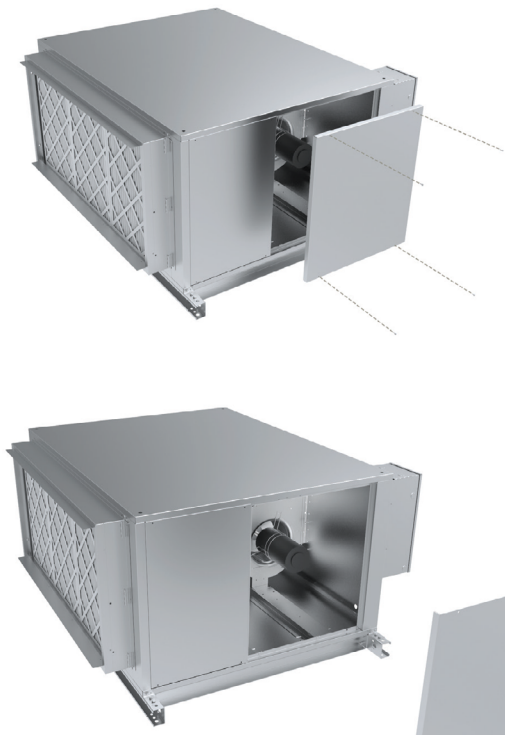

### MOTOR/BLOWER ASSEMBLY

The type of fan operation is determined by the control components and their method of wiring and may vary from unit to unit. Refer to the wiring diagram for each unit for that unit's individual operating characteristics. The direct drive blower coil fan's EC motors are permanently lubricated and do not require field lubrication. Check periodically that all motor hardware is properly fastened and clear of all dirt and dust.

Should the assembly require extensive service, the motor/blower assembly may be removed from the unit to facilitate such operations as motor or blower wheel/housing replacement, etc. Dirt and dust should not be allowed to accumulate on the blower wheel or housing. This can result in an unbalanced blower wheel condition that can damage a blower wheel or motor. The wheel and housing may be cleaned periodically using a vacuum cleaner and a brush taking care not to dislodge the factory balancing weights on the blower wheel blades. To remove blower/motor, follow steps illustrated in Figures 5a-5d. Due to opposing set screw and belly band locations, both access panels must be removed or fully opened for blower/motor removal.

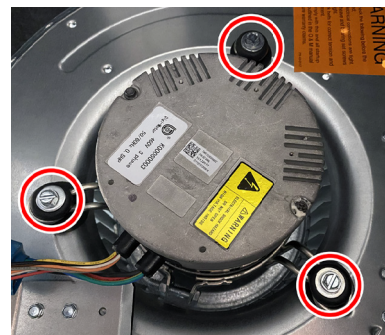

## COIL

The entering air side of the coil may be cleaned in place by removing the filters from the unit, accessing from the inlet, and then brushing the coil face between fins with a soft brush parallel to fins. To clean the leaving air side of the coil, gain entry through the access door and then follow the same brushing procedure. Do not brush perpendicular to fin orientation as damage may occur. Brushing should be followed by cleaning with a vacuum cleaner. If a compressed air source is available, the coil may also be cleaned by blowing air through the coil fins from the leaving air face. Vacuuming should again follow this. Units provided with proper type of air filters, replaced regularly, may require periodic coil cleaning.

## ELECTRIC RESISTANCE HEATER ASSEMBLY

Electric resistance heaters typically require no normal periodic maintenance when unit air filters are changed properly. Other conditions and equipment may affect the operation and service life in the system. The two most important operating conditions for an electric heater are proper airflow and proper supply voltage. High supply voltage and/or poorly distributed or insufficient airflow over the element will result in element overheating. This condition may result in the heater cycling on the high limit thermal cutout. Open wire type heaters provided have an automatic reset switch with a back-up high limit thermal switch. Automatic reset switches are as the name implies; they reset automatically after the heater has cooled down. The high limit thermal cutout device is a manual reset safety device. With proper unit application and during normal operation, the high limit thermal cutout will not operate. This device only operates when some problem exists. ANY condition that causes high limit cutout MUST be corrected immediately. Once the high limit trips, it may be reset once the unit has cooled down. Refer to troubleshooting section for high limit reset instructions. High supply voltage also causes excessive amperage draw and may result in tripping of the circuit breaker or blowing of the fuses on the incoming power supply.

## ELECTRICAL WIRING & CONTROLS

The electrical operation of each unit is determined by the components and wiring of the unit and may vary from unit to unit. Consult the wiring diagram for the actual type and number of controls provided on each unit. The integrity of all electrical connections should be verified at least twice during the first year of operation. Afterwards, all controls should be inspected regularly for proper operation. Some components may experience erratic operation or failure due to age. Wall thermostats may also become clogged with dust and lint and should be periodically inspected and cleaned to provide reliable operation. Please refer to controls manufacturer's IOM for periodic maintenance instructions.



For units configured with an uninsulated blow-thru heat section: To prevent sweating, ensure that insulation is field-installed prior to cooling mode operation.



When replacing any components such as fuses, contactors, or relays, use only the exact type, size, and voltage component as furnished from the factory. Any deviation without factory authorization could result in personnel injury or damage to the unit and will void all factory warranties and listings. All repair work should be done in such a manner as to maintain the equipment in compliance with governing codes and ordinances or testing agency listings.



More specific information regarding the use and operating characteristics of the standard controls offered by this manufacturer is contained in other manuals.

### FILTERS, THROWAWAY

The type of throwaway filter most commonly used on blower-coil units should be replaced on a regular basis. The time interval between each replacement should be established based on regular inspection of the filter and should be recorded in the log for each unit. Refer to the chart below for recommended filter size for each product type and size. If the replacement filters are not purchased from the factory, the filters used should be the same type and size as that furnished from or recommended by the factory. Consult the factory for applications using filter types other than the factory standard or optional product.

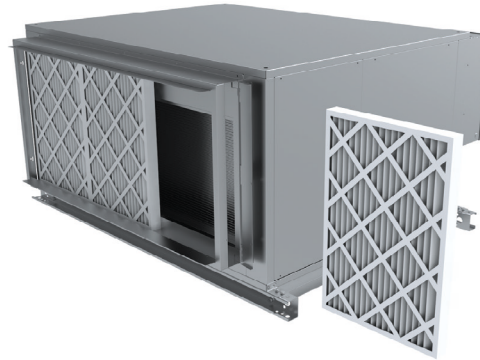

TABLE 3: FACE AREA, FREE AREA & FILTER SIZES

Unit Size	Coil Face Area	2" Flat Filters (Quantity) & Size	Filter Face Area
08	2.1 (0.20)	(1) 15.75 x 19.75 x 2 (400 x 502 x 51)	2.2 (0.20)
12	2.7 (0.25)	(1) 15.75 x 24.75 x 2 (400 x 629 x 51)	2.7 (0.25)
16	3.5 (0.33)	(2) 15.75 x 19.75 x 2 (400 x 502 x 51)	4.3 (0.40)
20	4.9 (0.46)	(1) 15.75 x 19.75 x 2 (400 x 502 x 51) (1) 15.75 x 24.75 x 2 (400 x 629 x 51)	4.9 (0.46)
30	6.5 (0.60)	(2) 24.75 x 15.75 x 2 (629 x 400 x 51) (1) 24.75 x 19.75 x 2 (629 x 502 x 51)	8.8 (0.82)
40	8.4 (0.78)	(3) 24.75 x 19.75 x 2 (629 x 502 x 51)	10.2 (0.95)

Notes:

1. Standard filters are 2" throwaway
2. Filter sizes are nominal and standard size, measure in inches (millimeters)
3. Coil and filter face areas are measured in square feet (square meters)
4. Cooling and heating coils have same face area



## DRAIN

The drain should be checked before initial start-up and at the beginning of each cooling season to assure that the lines are clear. If it is clogged, steps should be taken to clear the debris so that condensate will flow easily. Periodic checks of the drain should be made during the cooling season to maintain a free flowing condensate.

Should the growth of algae and/or bacteria be a concern, consult an air conditioning and refrigeration supply organization familiar with local conditions for chemicals available to control these agents. If cleaners are used, they should be compatible with the materials of construction for the coil and drain pan.

## CONDENSATE FLOAT SWITCH INSTALLATION

Ensure float switch assembly is firmly secured to the bracket. Ensure top of float is below rim of pan. Switch will trip when the water level reaches a point even with top of float when float is in the down position.

Sensitivity may be adjusted by threading switch assembly downward out of bracket if necessary. Test switch by lifting float with unit on. Unit should stop running if switch is correctly wired. Test switch sensitivity by filling pan and confirm switch stops unit before pan overflows.

Supplier's install instructions

1. Disconnect power to unit at main panel.
2. Clip switch bracket onto side of pan at low end and press firmly into place ensuring switch wires are positioned up ensure float moves freely.
3. Secure bracket into side of pan using self-tapping sheet metal screw through upper hole in bracket.
4. Ensure float switch assembly is firmly secured to bracket. Ensure top of float is below rim of pan. Switch will trip when water level reaches a point even with top of float (when float is in down position). Sensitivity may be adjusted by threading switch assembly downward out of bracket if necessary.
5. Ensure wiring matches the wiring diagram provided with the unit.
6. Test switch by lifting float with unit on. Unit should stop running if switch is correctly wired.
7. Test switch sensitivity. Fill pan and confirm that switch stops unit before pan overflows.
8. Follow all Lock-Out Tag-Out procedures when performing condensate float switch maintenance.

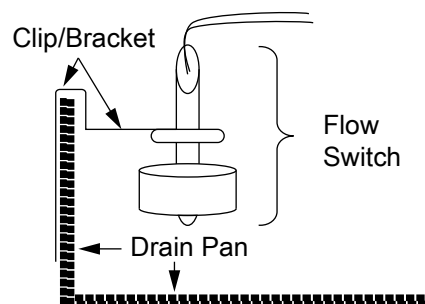
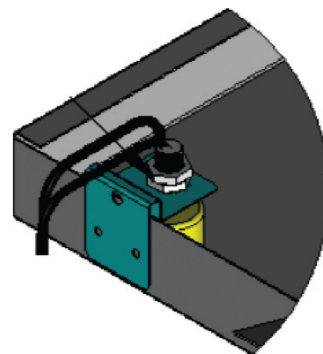

## REPLACEMENT PARTS

Factory replacement parts should be used where possible to maintain the unit performance and operating characteristics and the testing agency listings. Replacement parts may be purchased through the local Sales Representative.

Contact the local Sales Representative before attempting any unit modifications. Any modifications not authorized by the factory could result in personnel injury and damage to the unit and could void all factory warranties and regulatory listings.

On warranty replacements, in addition to the information previously listed, the project CO # that appears on the unit nameplate, is required. Contact local Sales Representative and refer to warranty policy.

All equipment and components sold through the Parts Department are warranted under the same conditions as the standard manufacturer's warranty with the exception that the warranty period is 12 months.

When ordering parts, the following information must be supplied to ensure proper part identification:

1. Complete unit model number
2. Unit hand connection (right or left hand) while facing the direction of airflow at the inlet
3. Complete part description including any numbers

## SECTION FOUR - DISCRETE COMPONENTS

### FAN MOTOR CONTROL

Unit control with discrete components consists of a transformer, fan enable relay and terminal strip for customer and peripheral connections. The transformer will vary in primary voltage depending on each unit's ordered options. The transformer will always have a 24VAC secondary voltage. An optional Hand-Off-Auto switch may be used to provide manual and automatic control of the fan.

A PWM board will provide the motor control signal to the motor. Refer to EC Motor Solo, Select and Sync PWM IOM, All Products for more information about the PWM and EC motors.

Peripheral devices (e.g., thermostat controllers, electric heat relays, water valve actuators, condensate drain pan float switches, air dampers) are connected by either the OEM or by the installer at the terminal strip.

### INSTALLATION

#### MOUNTING

Important: Do not over tighten the screws. Over tightening may strip the threads and will void the warranty.

Using #8 screws, install the components using the provided mounting holes for each component.



#### Risk of Electric Shock

Disconnect or isolate all power supplies before making electrical connections. More than one disconnection or isolation may be required to completely de-energize equipment. Contact with components carrying hazardous voltage can cause electric shock and may result in severe personal injury or death.

#### WIRING

Install the wiring so it does not cause a hazard, and is protected against electrical and mechanical damage.



#### Risk of Electric Shock

Ground the transformer according to local, national, and regional regulations. Failure to ground the transformer may result in electric shock and severe personal injury or death.

# REFERENCE WIRE DIAGRAM

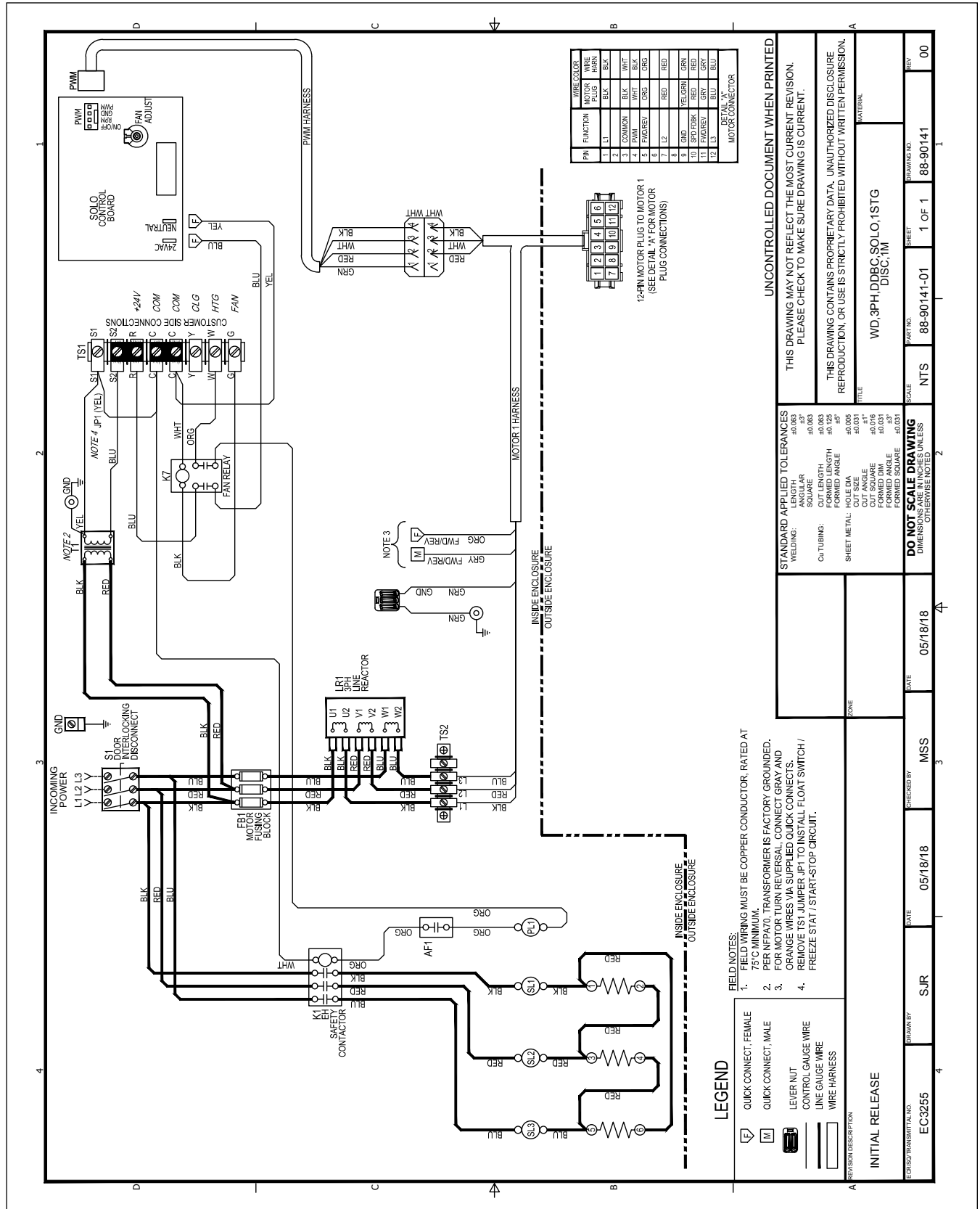

TABLE F.1 – TERMINAL STRIP IDENTIFICATION

Pin	Signal	Pin	Description
1	S1	Common	Common side of transformer. Jumped to C (common) through JP1. If application calls for float switch JP1 is re-moved and float switch is connected between S1 and C.
2	S2	24 VAC	Transformer secondary “hot” connection (24VAC). In most cases, these 3 R terminals are internally connected on the terminal strip.
3	R		
4	C	Common	Low voltage common. These terminals are internally connected on the terminal 5 C strip.
5	C		
6	Y	Cool	Chilled water valve actuator control input, and thermostat cooling output.
7	W	Heat	Wire connection point for hot water valve actuator or 1st stage EH control input, and thermostat heating output.
8	G	Fan Enable	Used to allow external start-stop control from an external source

TOOLS NEEDED FOR INSTALLATION/TROUBLESHOOTING

- Digital multimeter capable of measuring 30 volts AC
- Screwdriver
- Fuse puller (optional)

TABLE F.2 – FIELD INSTALLED COMPONENT DESCRIPTIONS

Name	Description
Field-provided Float Switch	To install a float switch, wire the float switch leads into S1 and C on the screw terminals. After wiring the float switch, remove jumper JP1. The JP1 jumper must be removed for the float switch to operate correctly.  Note: If a float switch was installed in the factory, the float switch may be connected through a factory-provided harnesses.
Start/Stop for the fan	To start or stop the fan from an external controller, wire the leads for the switch contacts that will be made or broken to R and G on the screw terminals. After wiring the switch, verify no jumper is installed between R and G.
Remote 3-speed switch (Requires SELECT PWM board)	To add a remote 3-speed switch, remove the jumper between 24VAC and SPD3. Then wire the leads for the switch to 24VAC, SPD3 (High), SPD2 (Med) and SPD1 (Low) on the Select PWM board.

TABLE F.3 – JUMPER DESCRIPTION

Jumper	Name	Description
JP1	Float Switch Jumper	This jumper is installed between S1 and C when a float switch is not installed. The jumper is removed when a float switch is installed.

## CHECKING WIRE HARNESES

To check three phase EC motor harness:

- Remove power from unit.
- Refer to wiring diagram.
- Unplug 12 pin wire harness connector from motor.

Note: 1.5HP and larger motors have separate motor controller. In this case, disconnect the 12 pin wire harness from motor controller.

- Disconnect the black, red, and blue harness wires from the terminal strip in the electrical enclosure.
- Unplug the PWM wire harness from the motor harness.
- Verify continuity of wires on motor harness per detail 'A' on wire diagram, then reconnect.

To check single phase EC motor harness:

- Remove power from unit.
- Refer to wiring diagram.
- Unplug 5 pin motor power wire harness connector from motor.
- Disconnect motor power harness wires from the lever nuts in the electrical enclosure.
- Verify continuity of wires, then reconnect.

To check EC motor PWM harness:

- Remove power from unit.
- Refer to wiring diagram.
- Unplug PWM wire harness from motor (single phase units) or from motor harness (three phase units).
- Unplug PWM wire harness from PWM board.
- Verify continuity of wires, then reconnect.

To check electric heat harness (dual blower units with electric heat):

Note: electric heat wire harness connects far side (second blower) heater to near side electrical enclosure.

- Remove power from unit.
- Refer to wiring diagram.
- Unplug electric heat wire harness at electrical enclosure.
- Verify resistance across pin 1 and pin 2 of wire harness. Near zero resistance indicates a shorted far side heater. Near infinity resistance indicates a far side heater open circuit. Reconnect.

To check motor harness:

- Refer to wiring diagram.
- Remove power from the unit. Unplug motor harness 12 pin connector at motor or motor controller.
- Unplug motor harness from motor connection or PWM board (depending

To check low voltage wire harnesses:

- Remove power from the unit. Unplug low voltage harness J1 connector and disconnect connections at other end of J1 harness.
- Use ohmmeter to check continuity for each conductor, then reconnect harness to J1 connector and to other connections.

Before reconnecting power to unit, verify all harnesses are connected per diagram.

Use caution when inserting meter probe into plug. Excess force will damage contacts.



### Risk of Electric Shock

Disconnect or isolate all power supplies before making electrical connections. More than one disconnection or isolation may be required to completely de-energize equipment. Contact with components carrying hazardous voltage can cause electric shock and may result in severe personal injury or death.

No routine maintenance is required for the discrete components.

TABLE F.4 – FAN MOTOR CONTROL

Jumper	Name	Description
No 24 VAC Power	No jumper between R and G without external start/stop control installed	Verify that either an external start/stop or jumper between R and G is installed. If neither, install one of them.
	JP1 removed without float switch or low temperature sensor installed	Verify that either a float switch, low temperature sensor or JP1 are installed. If none, install one of them.
	Float switch or low temperature sensor tripped	Verify float switch and/or low temperature sensor (if present) are made.
	Incorrect incoming line voltage	Verify incoming voltage to the unit per unit nameplate. Supply voltage must be within +/- 5% of unit nameplate.
	Damaged transformer	Verify the secondary transformer voltage between R and S1 is 24VAC $\pm$ 10%. If not, verify primary transformer voltage is within tolerance. If the primary voltage is within tolerance and the secondary voltage is not, replace the transformer.
	Improper wiring connections	Verify that the unit is wired per the unit wiring diagram for incoming voltage. If the unit includes main fusing, verify that the fuses are not blown. Verify wire harness connections are secure. See "Checking Wire Harnesses" section.
Fan motor will not run	No 24 VAC Power	See above
	Hand-Off-Auto (HOA) switch is set to Off	Verify the HOA switch is not set to OFF
	Fan speed is not commanded	Verify a fan enable is commanded from either jumper between R and G, a unit-mounted or remote-mounted three speed switch, or a thermostat.
Electric heat signal is not provided to contactor	Fan speed is not commanded	Verify that fan motor is running. A fan speed must be commanded to allow the electric heat contactor to energize on a call for heat.

## SECTION FIVE - TROUBLESHOOTING

### EC MOTOR TROUBLESHOOTING GUIDELINES

For EC Motor troubleshooting questions please refer to the “EC Motor Solo, Select, and Sync PWM IOM, All Products” document found under the IOM Literature section of [www.Superior Rex-hvac.com](http://www.Superior Rex-hvac.com).

### COOLING SYSTEM TROUBLESHOOTING GUIDELINES

Problem	Possible Cause	Corrective Action
Insufficient cooling	Insufficient airflow	Verify proper airflow
	Dirty water coil	Check cleanliness of water coil. Clean as needed.
	Drain pan float switch fault	Verify operation of drain pan float switch, if present. Disconnect switch and use volt-ohm meter to verify continuity of switch and of wiring. Replace switch if faulty.
	Cooling valve not operating properly	Verify cooling valve opens with call for cooling. Verify all manual valves are open.
	Insufficient airflow	Verify liquid flow per system design
	Obstructed coil	Verify coil is unobstructed. Verify all manual valves are open and have liquid flow through system.
	(DX coils) Improper refrigerant charge	Charge to proper cooling
	(DX coils) Insufficient cooling liquid to coil	Verify coolant flow in coil. Verify proper flow per system design.
	No call for cooling	Verify cooling signal at 'Y' terminals. Verify thermostat setting/operation.
Unit sweats	Air leak in ducts/unit	Verify integrity of unit. Verify ducts are properly sealed.
	Pipe insulation	Verify pipes are properly insulated
	Damaged insulation	Verify insulation at point of sweating
	Unconditioned air to unit	Verify conditioned air to unit
	Drain pan is clogged	Locate and remove blockage

## ELECTRIC HEATER TROUBLESHOOTING GUIDELINES

Problem	Possible Cause	Corrective Action
<p>Electric Heat will not operate</p> <p><b>CAUTION:</b> UNIT MAY BE EXTREMELY HOT. TAKE GREAT CARE WHILE TROUBLESHOOTING</p>	Insufficient airflow	Verify that airflow is sufficient to provide a minimum of 70 CFM per kW of electric heat. Heater is not designed to operate below 70 CFM/kW.
	Loss of demand	Verify that heat command signal is not dropping out. Re-view schematic. For standard heaters, verify 24VAC at heater control 'W' terminal. For multi-stage units, verify demand at W and S2 terminals. For units with proportional heater control, verify analog signal at COM and SIG terminals of Heat controller.
	Loss of 24VAC	Verify 24V at transformer and at 'R' terminal.
	No airflow	Electric heat will not operate unless fan motor is enabled. Possible loose wiring. Verify integrity of wiring to TS1 terminal. Possible loss of fan command. Verify fan relay is enabled - 24VAC at coil of fan relay. Possible bad fan relay. If fan relay is enabled but doesn't actuate, replace relay. Possible Hand-Off-Auto switch fault (if present). If Hand-Off-Auto switch is in Hand position and 24VAC doesn't pass to fan relay, replace HOA switch.
	Primary limit switch tripped	Verify no loss of demand to unit. Verify that voltage exists on magnetic heater contactor during demand for heat. If demand reaches unit but not contactor, primary limit is tripped. It is an automatic reset limit switch that guards against overheating as a resulting of insufficient air passing over the limit switch. The primary limit switch(es) will auto-reset once the unit cools down. This may take up to an hour. NOTE: dual blower units have two heater racks and two primary limits.
	Primary limit faulted or damaged wire/wire harness	Remove power from unit. Wait for unit to cool down. Disconnect primary limit wire or wire harness (refer to wire diagram for unit.) Verify continuity across primary limit. If primary limit is verified good, verify continuity across wire or harness and to each side of primary limit. If no continuity, replace wires or wire harness.
	Secondary (high) limit switch tripped	The secondary limit may be manually reset. If unit is hot, wait for the heater to cool down. This may take up to an hour. Reset switch(es). Verify if heater will start.
	Improper wiring connections	Verify wiring per wire diagram
	Open or damaged heater elements	With power removed, inspect the heating elements, disconnect heater wire harnesses. (The harnesses with the black plug.) Use a volt-ohm meter to measure resistance across the electric heat power harness coming out of the heater section. If the meter measures an open or shorted circuit, replace with new elements.
	Damaged electric heat wire harness	With power removed, disconnect heater wire harnesses. Use a volt-ohm meter to verify continuity of electric heat power harness wires in the control enclosure section.
Secondary (high) Limit switch fault	Remove power from unit. Wait for unit to completely cool down. This may take up to an hour. Remove secondary limit switch from circuit. Verify continuity across (cooled) switch terminals. Replace switch if no continuity.	



## ELECTRIC HEATER TROUBLESHOOTING GUIDELINES

Problem	Possible Cause	Corrective Action
<p>Electric Heat will not operate</p> <p><b>CAUTION:</b> UNIT MAY BE EXTREMELY HOT. TAKE GREAT CARE WHILE TROUBLESHOOTING</p>	(Magnetic contactor) Electric heat contactor fault	Verify heating demand voltage is at magnetic electric heat contactor control coil terminals. If power is present but contactor is not actuated, replace contactor. To verify contactor: with power removed, unwire contactor and verify continuity across contacts when manually operated. Cover of contactor may need to be removed to access manual operator. Replace contactor if faulty.
	Contactor chattering	Possible insufficient airflow. Verify unit develops minimum required CFM. Possible turbulent airflow. Verify ductwork complies with ASHRAE Fundamentals Handbook, SMACNA, NFPA 90A and local code. Possible undersized transformer. Verify 24V AC voltage.
	(Solid state relay) electric heat safety contactor fault	Verify 24V AC control voltage is at magnetic electric heat safety contactor control coil terminals. If power is present at coil but contactor is not actuated, replace contactor. If power is not present at coil, verify primary limit switch.
	(On/Off Solid state relay) Solid State Relay fault	Verify heating demand (24VAC control voltage) is at solid state relay control terminals. If power is present but relay is not actuated, replace relay.
	(Solid state relay with proportional control) Heat controller fault	Verify analog DC control signal is present at controller SIG and COM input terminals. Verify that output control voltage to solid state relay varies with variation in analog input. Replace controller if not.
	(Solid state relay with proportional control) Solid State Relay fault	If proportional heat controller not faulted, verify solid state relay has DC control voltage at relay terminals. If control voltage at terminals and relay fails to pass voltage from safety contactor to heater, solid state relay is faulted. Replace relay.
<p>Electric Heat shuts down unexpectedly</p>	Loss of demand	Verify that heat command signal is not dropping out. Review schematic. For standard heaters, verify 24VAC at heater control 'W' terminal. For multi-stage units, verify demand at W and S2 terminal. For units with proportional heater control, verify analog signal at COM and SIG terminals of Heat controller.
	Loss of fan speed command	Heater will not operate if fan is not enabled. Verify 24VAC at fan relay coil and contact with EH command wire.
	Insufficient airflow	Unit must have sufficient airflow to allow airflow switch to make. Verify airflow switch is enabled: there should be 24VAC present at each side of switch while fan is running.
	Primary limit switch tripped	24VAC on EH signal wire but not at airflow switch signifies primary limit has tripped. The primary limit switch(es) will auto-reset once the unit cools down. This may take up to an hour. If limit trips again, verify heater is not overheating. NOTE: dual blower units have two primary limits.
	Secondary (high) limit switch tripped	The secondary limit may be manually reset. If unit is hot, wait for the heater to cool down. This may take up to an hour. Reset switch(es). If limits trip again, verify heater is not overheating. NOTE: dual motor units have two heater racks.
	Intermittent control device	Verify operation of any control device such as drain pan float switch, freeze stat, etc. When in doubt, jumper out and verify fan operation.
	Loose wiring	Remove power from unit. Verify and/or tighten all wiring connections.

## ELECTRIC HEATER TROUBLESHOOTING GUIDELINES

Problem	Possible Cause	Corrective Action
<p>Electric heater is overheating</p> <p><b>CAUTION:</b> UNIT MAY BE EXTREMELY HOT. TAKE GREAT CARE WHILE TROUBLESHOOTING</p>	Insufficient airflow	Verify that airflow is sufficient to provide a minimum of 70 CFM per kW of electric heat. Heater is not designed to operate below 70 CFM/kW.
	Improper duct connections	Electric heaters require even airflow across the face of the heater in order to operate properly. Verify ductwork is installed per SMACNA and ASHRAE guidelines.
	Obstructed ductwork	Verify no obstructions. Verify all dampers are full open while fan operates.
	Intermittent fan	Verify fan motor runs continuously, providing even airflow.
	Incorrect voltage applied	Verify proper voltage to unit per unit label.
	Improper wiring connections	Verify wiring to schematic. Verify all jumpers installed on terminal strip per schematic.
	Damaged heater elements	Remove power from unit. Access the heater compartment. Verify heating elements are undamaged.
	Safety magnetic heater contactor short	Remove heater command signal. Verify loss of 24VAC at heater contactor. If electric heat continues to operate and all wiring has been verified, replace contactor.
<p>Insufficient heating</p> <p><b>INSUFFICIENT HEATING</b> <b>CAUTION:</b> UNIT MAY BE EXTREMELY HOT. TAKE GREAT CARE WHILE TROUBLESHOOTING</p>	Solid State heater relay (SSR) short	Remove heater command signal. Verify loss of 24VAC at SSR. If electric heat continues to operate and all wiring has been verified, replace contactor.
	Intermittent demand for heating. Heater short cycling	Review schematic. For standard heaters, there needs to be continuous 24VAC at heater control 'W' terminal during demand for heat. For multi-stage units, verify continuous demand signal at W and S2 terminal. For units with proportional heater control, verify continuous analog signal at SSR COM and SIG terminals.
	Open or damaged heater elements	Remove power. Access heater compartment to inspect heater coils. Note that dual motor units have two separate heater racks.
	Loss of stage	Loss of demand for second stage. Verify 24VAC at coil for stage 2 contactor.
	Incorrect voltage applied	Verify proper voltage to unit per unit label
	Electric heat contactor fault	Verify 24VAC at coil terminal for each electric heat contactor. If power is present but contactor is not actuated, replace contactor. To verify contactor: with power removed, unwire contactor and verify continuity across contacts when manually operated. Cover of contactor may need to be removed to access manual operator. Replace contactor if faulty.
	Contactor chattering	Possible insufficient airflow. Verify unit develops minimum required CFM. Possible turbulent airflow. Verify ductwork complies with ASHRAE Fundamentals Handbook, SMACNA, NFPA 90A and local code. Possible under sized transformer. Verify 24VAC voltage.
Primary limit switch cycling	24VAC on EH signal wire but not at airflow switch signifies primary limit has tripped. If limit continues to trip, verify that heater is not overheating. Verify sufficient airflow and proper ductwork connections. NOTE: dual blower units have two heater racks and two primary limits.	

## SECTION SIX - INSPECTION & START-UP CHECKLIST

### RECEIVING & INSPECTION

- Unit Received Undamaged
- Unit Arrangement/Hand Correct

### HANDLING & INSTALLATION

- Unit Mounted Level & Square
- Proper Electrical Service Provided
- Proper Service Switch/Disconnect Provided
- Proper Chilled Water Line Size to Unit
- Proper Refrigerant Line Sizes to Unit
- Proper Steam Condensate Trap on Return Line
- All Services to Unit in Code Compliance

### COOLING/HEATING CONNECTIONS

- Protect Valve Package Components from Heat
- Connect Field Piping to Unit
- Install Drain Line & Traps as Required
- Install Condensate Pan under Piping as Required

### DUCTWORK CONNECTIONS

- Install Ductwork, Fittings & Grilles as Required
- Control Outside Air for Freeze Protection

### ELECTRICAL CONNECTIONS

- Refer to Unit Wiring Diagram
- All Field Wiring in Code Compliance

### UNIT STARTUP

- General Visual Unit & System Inspection
- Record Ambient Temperature
- Close All Unit Isolation Valves
- Fill Systems with Water/Refrigerant
- All Ductwork & Grilles in Place
- Start Fans, etc
- Check All Ductwork & Units for Air Leaks
- Record All Final Settings for Future Use
- Check All Dampers for Proper Operation
- Verify Proper Heating Operation

### BLOWER/MOTOR

- Check Blower Wheel Set Screw Tightness
- Unit Received Complete as Ordered
- Unit Structural Support Complete & Correct
- Proper Access Provided for Unit & Accessories
- Proper Over current Protection Provided
- Proper Hot Water Line to Unit
- Proper Steam Line Sizes to Unit
- Proper Steam Supply Pressure to Unit (15psi Max)
- All Shipping Screws & Braces Removed
- Mount Any Field Provided Valve Packages
- Pressure Test All Piping for Leaks
- Insulate All Piping as Required
- Proper Supply & Return Grille Type & Size Used
- Insulate All Ductwork as Required
- Connect Incoming Power Service or Services
- Tighten All Wiring Connections Before Applying Power
- Record Electrical Supply Voltage
- Check All Wiring for Secure Connections
- Flush Water Systems
- Vent Water Systems as Required
- All Unit Panels & Filters in Place
- Check for Overload Condition of All Units
- Balance Air Systems as Required
- Check Piping & Ductwork for Vibration
- Verify Proper Cooling Operation
- Reinstall All Covers & Access Panels
- Check Blower Speed As Necessary For Balancing Airflow

